

RIVET NUTS CATALOGUE

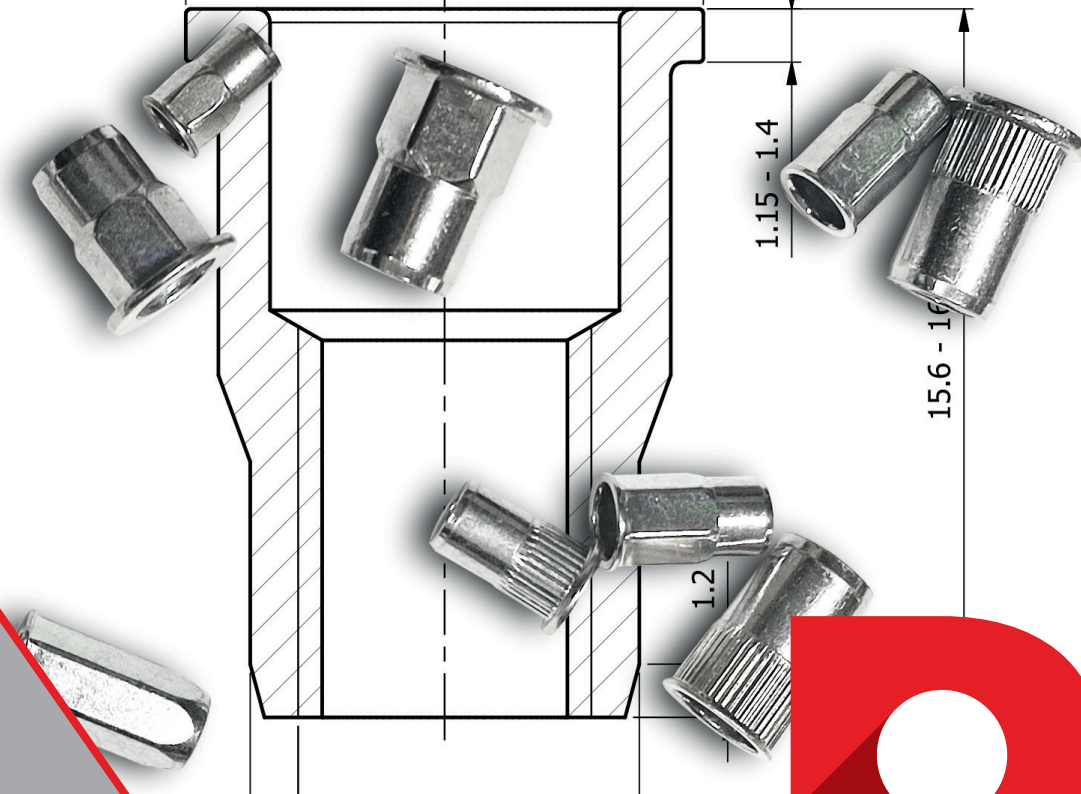

Ed. 02 - 2024



DEFREMM
COLD FORMING EXPERT

DEFREMM S.p.A.



Via Goito, 6 - 23900 Lecco LC



Tel. (+39) 0341 251410



info@defremm.it

Rivet nut code No. key 4

CATALOGUE

- Zinc plated steel rivet nut open - flat shank cylindrical head
IAACM L1 CLTC - IAACM L2 CLTC 6
- Zinc plated steel rivet nut closed - flat shank cylindrical head
ICACM L1 CLTC - ICACM L2 CLTC 7
- Zinc plated steel rivet nut open - flat shank reduced head
IAACM L1 CLTF - IAACM L2 CLTF 8
- Zinc plated steel rivet nut closed - flat shank reduced head
ICACM L1 CLTF - ICACM L2 CLTF 9
- Zinc plated steel rivet nut closed - flat shank countersunk head
ICACM L1 CLTS - ICACM L2 CLTS 10
- Zinc plated steel rivet nut open - knurled shank cylindrical head
IAACM L1 CZTC - IAACM L2 CZTC 11
- Zinc plated steel rivet nut closed - knurled shank cylindrical head
ICACM L1 CZTC - ICACM L2 CZTC 12
- Zinc plated steel rivet nut open - knurled shank reduced head
IAACM L1 CZTF - IAACM L2 CZTF 13
- Zinc plated steel rivet nut closed - knurled shank reduced head
ICACM L1 CZTF - ICACM L2 CZTF 14
- Zinc plated steel rivet nut open - knurled shank countersunk head
IAACM L1 CZTS - IAACM L2 CZTS 15
- Zinc plated steel rivet nut closed - knurled shank countersunk head
ICACM L1 CZTS - ICACM L2 CZTS 16

- Zinc plated steel rivet nut open - semi-hexagonal shank cylindrical head
IAACM L1 SETC - IAACM L2 SETC 17
- Zinc plated steel rivet nut open - hexagonal shank cylindrical head
IAACM L1 TETC - IAACM L2 TETC 18
- Zinc plated steel rivet nut closed - hexagonal shank cylindrical head
ICACM L1 TETC - ICACM L2 TETC 19
- Zinc plated steel rivet nut open - hexagonal shank reduced head
IAACM L1 TETF - IAACM L2 TETF 20
- Zinc plated steel rivet nut closed - hexagonal shank reduced head
ICACM L1 TETF - ICACM L2 TETF 21
- Zinc plated steel rivet nut open - semi-hexagonal shank reduced head
IAACM L1 SETFE - IAACM L2 SETFE 22
- Zinc plated steel rivet nut closed - semi-hexagonal reduced head
ICACM L1 SETFE - ICACM L2 SETFE 23
- Zinc plated steel rivet nut open - semi-hexagonal shank reduced cylindrical head
IAACM L1 SETFC - IAACM L2 SETFC 24
- Stainless steel A2 rivet nut open - flat shank cylindrical head
IAA2M L1 CLTC 25
- Stainless steel A2 rivet nut closed - flat shank cylindrical head
ICA2M L1 CLTC 26
- Stainless steel A2 rivet nut open - flat shank reduced head
IAA2M L1 CLTF 27
- Stainless steel A2 rivet nut closed - knurled shank reduced head
ICA2M L1 CLTF 28
- Stainless steel A2 rivet nut open - knurled shank cylindrical head
IAA2M L1 CZTC - IAA2M L2 CZTC 29

INDEX

- Stainless steel A2 rivet nut closed - knurled shank cylindrical head
ICA2M L1 CZTC - ICA2M L2 CZTC 30
- Stainless steel A2 rivet nut open - knurled shank reduced head
IAA2M L1 CZTF - IAA2M L2 CZTF 31
- Stainless steel A2 rivet nut closed - knurled shank reduced head
ICA2M L1 CZTF - ICA2M L2 CZTF 32
- Stainless steel A2 rivet nut open - flat shank countersunk head
IAA2M L1 CLTS 33
- Stainless steel A2 rivet nut closed - knurled shank reduced head
ICA2M L1 CLTS 34
- Stainless steel A2 rivet nut open - knurled shank countersunk head
IAA2M L1 CZTS - IAA2M L2 CZTS 35
- Stainless steel A2 rivet nut closed - flat shank countersunk head
ICA2M L1 CZTS 36
- Stainless steel A2 rivet nut open - semi-hexagonal cylindrical head
IAA2M L1 SETC - IAA2M L2 SETC 37
- Stainless steel A2 rivet nut closed - semi-hexagonal cylindrical head
ICA2M L1 SETC - ICA2M L2 SETC 38
- Stainless steel A2 rivet nut open - semi-hexagonal reduced head
IAA2M L1 SETFE - IAA2M L2 SETFE 39
- Stainless steel A2 rivet nut closed - semi-hexagonal reduced head
ICA2M L1 SETFE - ICA2M L2 SETFE 40
- Stainless steel A2 rivet nut open - semi-hexagonal cylindrical head
IAA2M L1 SETFC - IAA2M L2 SETFC 41
- Stainless steel A2 rivet nut open - hexagonal shank cylindrical head
IAA2M L1 TETC 42

- Stainless steel A2 rivet nut closed - hexagonal shank cylindrical head
ICA2M L1 TETC 43
- Stainless steel A2 rivet nut open - hexagonal shank reduced head
IAA2M L1 TETF 44
- Stainless steel A2 rivet nut closed - hexagonal shank reduced head
ICA2M L1 TETF 45
- Aluminium rivet nut open - flat shank cylindrical head
IAALM L1 CLTC 46
- Aluminium rivet nut open - flat shank reduced head
IAALM L1 CLTF 47
- Aluminium rivet nut open - Knurled shank reduced head
IAALM L1 CZTF 48
- Aluminium rivet nut open - knurled shank cylindrical head
IAALM L1 CZTC 49

WARNING

We reserve the right to modify, without notice, the items shown in our catalogue in order to improve their quality

NOTE

*Figures obtained from tests carried out by our quality lab (+ / - 10%).
The measures shown in the table are to be considered as indicative of the normal value dimension*

RIVET NUTS CODE No. KEY

Cylindrical reduced head

Example code

IA AC M3 L1 CL TC

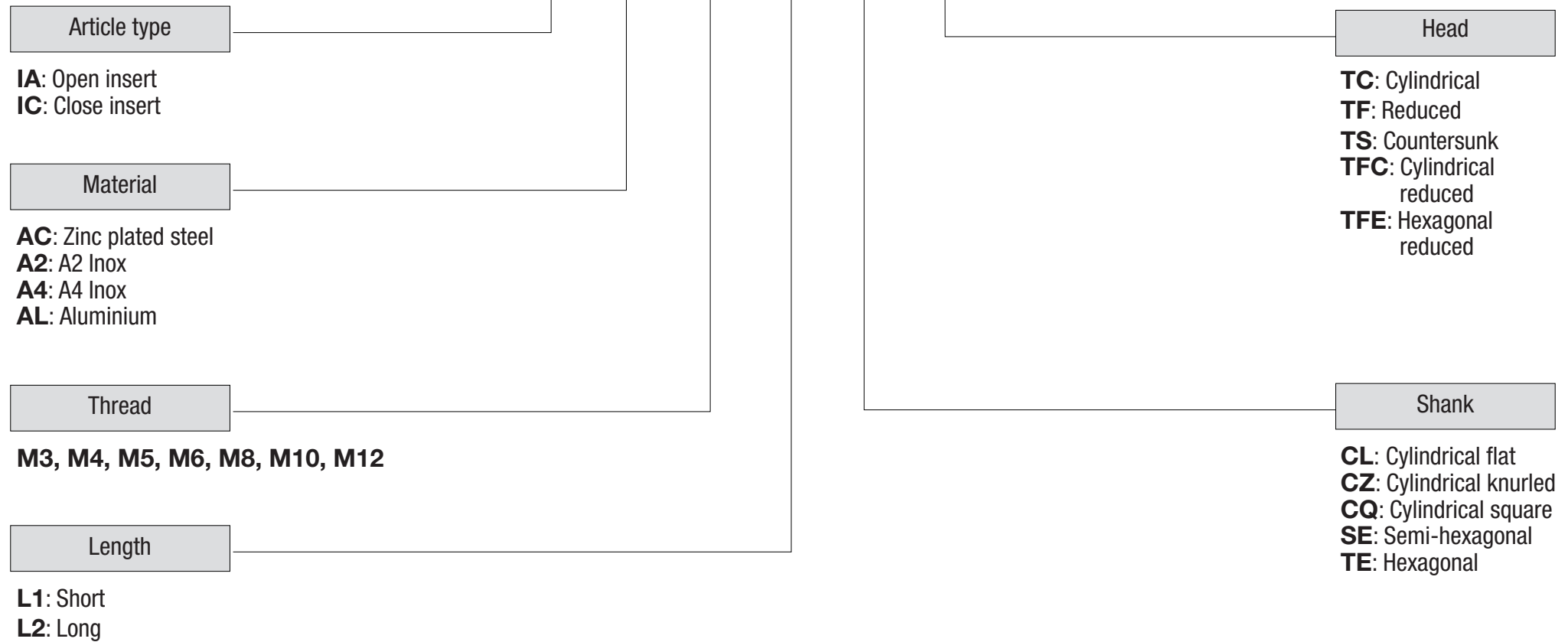

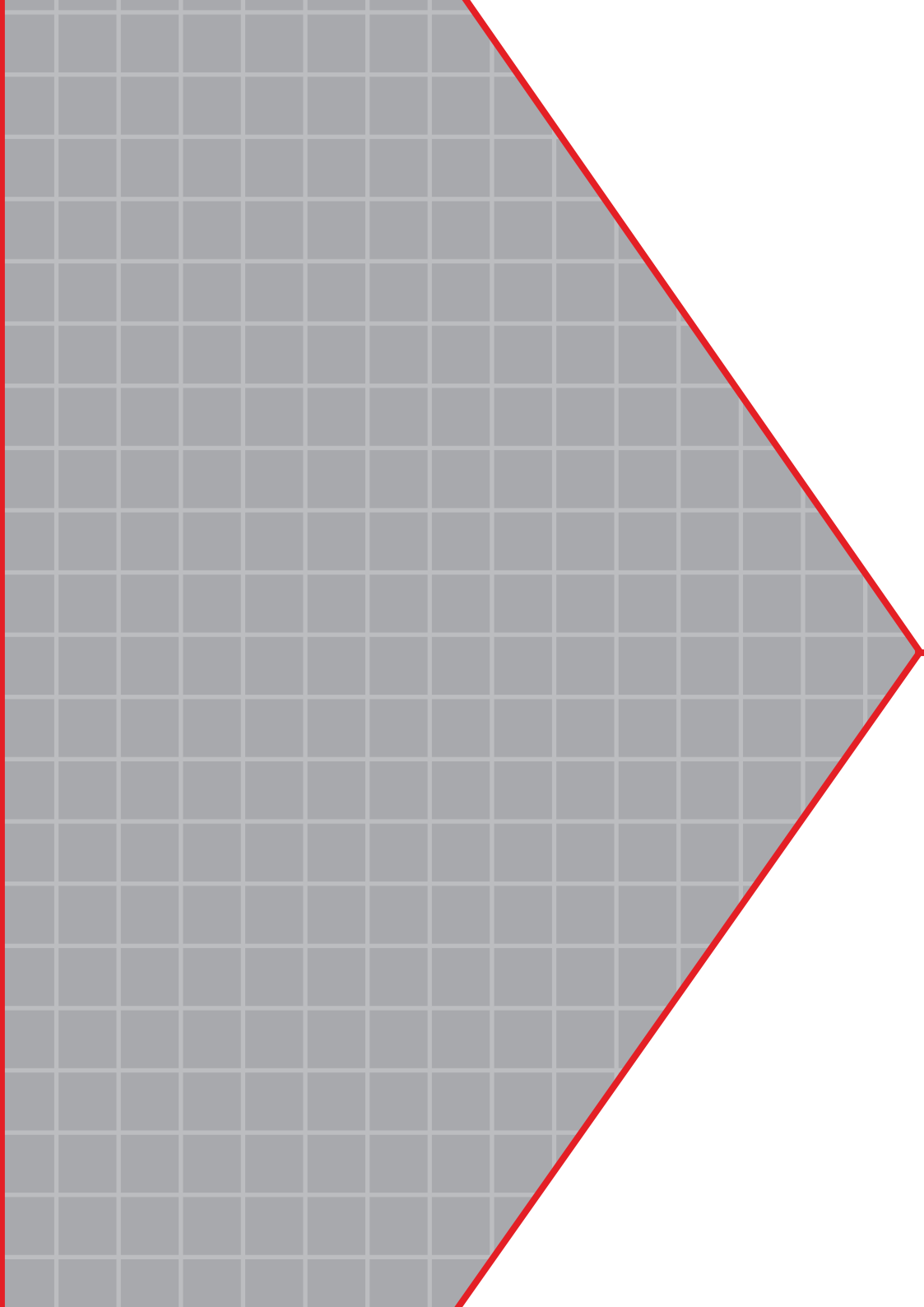

Catalogue



ZINC PLATED STEEL RIVET NUT OPEN - FLAT SHANK CYLINDRICAL HEAD

IAACM L1 CLTC
IAACM L2 CLTC

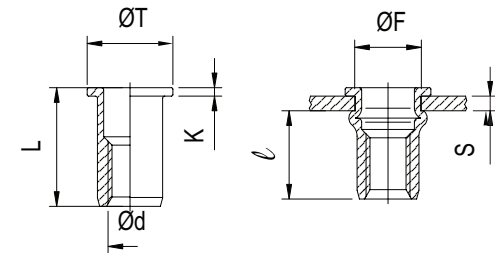

CODE	Thread Ød	S	ØF +0.10	Ø head (ØT)	Ø shank	K	L	ℓ	Tearing lead	cut	Max Torque Nm
IAACM3L1CLTC	M3	0,5 - 1,5	5	7,2	4,9	0,8	8,7	4,7	3900	900	2
IAACM3L2CLTC	M3	1,5 - 2,5	5	7,2	4,9	0,8	9,5	4,7	3900	900	2
IAACM4L1CLTC	M4	0,5 - 2	6	8,5	5,9	0,8	10,5	6	6800	1500	5
IAACM4L2CLTC	M4	2 - 3,5	6	8,5	5,9	0,8	12	6	6800	1500	5
IAACM5L1CLTC	M5	0,5 - 2,5	7	10	6,9	1	13	7,5	11500	2000	8,5
IAACM5L2CLTC	M5	2,5 - 5	7	10	6,9	1	17	8,5	11500	2000	8,5
IAACM6L1CLTC	M6	0,5 - 3	9	12,3	8,9	1,3	15,5	9,2	16500	3000	15
IAACM6L2CLTC	M6	3 - 5,5	9	12,3	8,9	1,3	18	6,2	16500	3000	15
IAACM8L1CLTC	M8	0,5 - 3,5	11	15	10,9	1,5	18,5	11,5	25000	4400	26
IAACM8L2CLTC	M8	3,5 - 6	11	15	10,9	1,5	21	11,5	25000	4400	26
IAACM10L1CLTC	M10	0,5 - 2,5	13	16,3	12,9	1,5	17	11,5	32000	5000	50
IAACM10L2CLTC	M10	2,5 - 4	13	17	12,9	1,6	21	12,5	32000	5000	50
IAACM12L1CLTC	M12	1 - 4	16	22	15,9	2	25	16	34000	6500	80
IAACM12L2CLTC	M12	4 - 6,5	16	18	14,9	1,7	25	13,5	34000	6500	80

ZINC PLATED STEEL RIVET NUT CLOSED - FLAT SHANK CYLINDRICAL HEAD

ICACM L1 CLTC
ICACM L2 CLTC

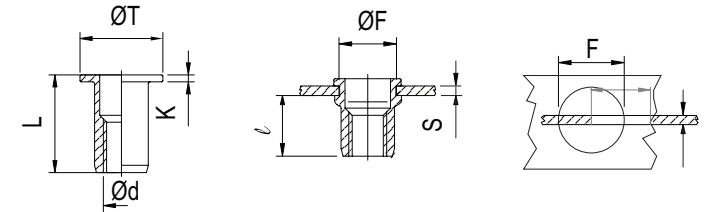

CODE	Thread Ød	S	ØF +0.10	Ø head (ØT)	Ø shank	K	L	ℓ	Tearing lead	cut	Max Torque Nm
ICACM3L1CLTC	M3	0,5 - 1,5	5	7,2	4,9	0,8	13,3	10	3900	900	2
ICACM4L1CLTC	M4	0,5 - 2	6	9	5,9	0,8	16	11,3	6800	1500	5
ICACM4L2CLTC	M4	2 - 4	6	9	5,9	0,8	18	11,3	6800	1500	5
ICACM5L1CLTC	M5	0,5 - 2,5	7	10	6,9	1	17	11,5	11500	2000	8,5
ICACM5L2CLTC	M5	2,5 - 5	7	10	6,9	1	19	11,5	11500	2000	8,5
ICACM6L1CLTC	M6	0,5 - 3	9	12,3	8,9	1,3	19,2	12,7	16500	3000	15
ICACM6L2CLTC	M6	3 - 5,5	9	12,3	8,9	1,3	21	12,7	16500	3000	15
ICACM8L1CLTC	M8	0,5 - 3	11	15	10,9	1,5	21,5	14,8	25000	4400	26
ICACM8L2CLTC	M8	3,5 - 5,5	11	15	10,9	1,5	24	14,8	25000	4400	26
ICACM10L1CLTC	M10	1 - 4	13	17	12,9	1,6	27	19,2	32000	5000	50

ZINC PLATED STEEL RIVET NUT OPEN - FLAT SHANK REDUCED HEAD

IAACM L1 CLTF
IAACM L2 CLTF

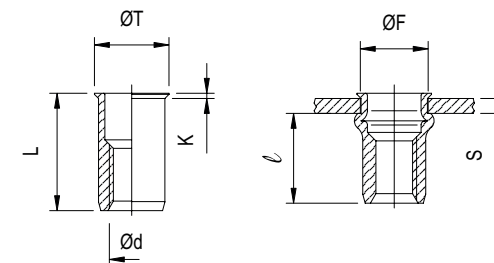

CODE	Thread Ød	S	ØF +0.10	Ø head (ØT)	Ø shank	K	L	ℓ	Tearing lead	cut	Max Torque Nm
IAACM3L1CLTF	M3	0,5 - 1,5	5	6	4,9	0,5	9	6,2	3900	900	1
IAACM4L1CLTF	M4	0,5 - 2	6	7	5,9	0,5	10,5	6,5	6800	1500	3
IAACM4L2CLTF	M4	2 - 4	6	7	5,9	0,5	13	6,5	6800	1500	3
IAACM5L1CLTF	M5	0,5 - 2	7	8	6,9	0,5	11,5	7	11500	2000	6
IAACM5L2CLTF	M5	2 - 4	7	8	6,9	0,5	13	7	11500	2000	6
IAACM6L1CLTF	M6	0,5 - 2,5	9	10	8,9	0,6	14	8,5	16500	3000	11
IAACM6L2CLTF	M6	2,5 - 5	9	10,5	8,9	0,6	17	8,5	16500	3000	11
IAACM8L1CLTF	M8	0,5 - 3	11	12	10,9	0,65	16,5	10	25000	4400	20
IAACM8L2CLTF	M8	3 - 5	11	12	10,9	0,65	18,5	10	25000	4400	20
IAACM10L1CLTF	M10	0,5 - 3	13	14,1	12,9	0,7	17,7	13	32000	5000	32
IAACM10L2CLTF	M10	3 - 5,5	13	14,1	12,9	0,7	21	13	32000	5000	32

ZINC PLATED STEEL RIVET NUT CLOSED - FLAT SHANK REDUCED HEAD

ICACM L1 CLTF
ICACM L2 CLTF

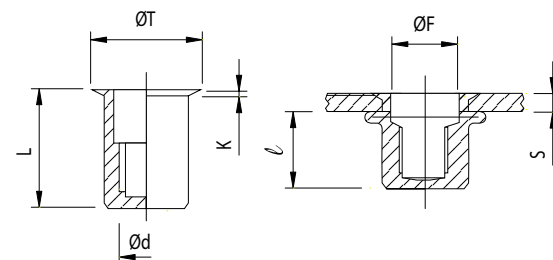

CODE	Thread Ød	S	ØF +0.10	Ø head (ØT)	Ø shank	K	L	ℓ	Tearing lead	cut	Max Torque Nm
ICACM4L1CLTF	M4	0,5 - 2	6	7	5,9	0,5	15	11	6800	1500	3
ICACM4L2CLTF	M4	2 - 3,5	6	7	5,9	0,5	16	11	6800	1500	3
ICACM5L1CLTF	M5	0,5 - 2	7	8	6,9	0,5	16,5	12,5	11500	2000	6
ICACM5L2CLTF	M5	2 - 3,5	7	8	6,9	0,5	17,5	12,5	11500	2000	6
ICACM6L1CLTF	M6	0,5 - 2,5	9	10	8,9	0,6	20,5	15,5	16500	3000	11
ICACM6L2CLTF	M6	2,5 - 4	9	10	8,9	0,6	22	15,5	16500	3000	11
ICACM8L1CLTF	M8	0,5 - 3	11	12	10,9	0,65	23	17	25000	4400	20
ICACM8L2CLTF	M8	2,5 - 4,5	11	12	10,9	0,65	24,5	17	25000	4400	20
ICACM10L1CLTF	M10	1 - 3	13	14,1	12,9	0,7	24,5	18,2	32000	5000	32
ICACM10L2CLTF	M10	3 - 5	13	14,1	12,9	0,7	26	18,2	32000	5000	32
ICACM12L1CLTF	M12	2 - 5	16	17,9	15,9	0,95	36	26	34000	6500	50

ZINC PLATED STEEL RIVET NUT CLOSED - FLAT SHANK COUNTERSUNK HEAD

ICACM L1 CLTS
ICACM L2 CLTS

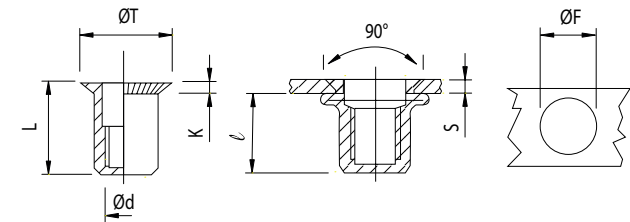

CODE	Thread $\varnothing d$	S	$\varnothing F$ +0.10	\varnothing head ($\varnothing T$)	\varnothing shank	K	L	ℓ	Tearing lead	cut	Max Torque Nm
ICACM4L1CLTS	M4	1,5 - 3	6	9	5,9	1,5	17,5	12,3	6800	1500	4
ICACM5L1CLTS	M5	1,5 - 3,5	7	10	6,9	1,5	19,5	14	11500	2000	8
ICACM6L1CLTS	M6	1,5 - 4	9	12	8,9	1,5	23,5	17,5	16500	3000	15
ICACM8L1CLTS	M8	1,5 - 4	11	14	10,9	1,5	26,5	20	25000	4400	26
ICACM8L2CLTS	M8	4,5 - 6,5	11	14	10,9	1,5	29,5	20	25000	4400	26
ICACM10L1CLTS	M10	1,5 - 5	13	16	12,9	1,5	30	21,5	32000	5000	45

ZINC PLATED STEEL RIVET NUT OPEN - KNURLED SHANK CYLINDRICAL HEAD

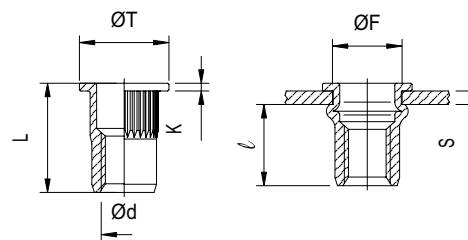
 IAACM L1 CZTC
 IAACM L2 CZTC

CODE	Thread Ød	S	ØF +0.10	Ø head (ØT)	Ø shank	K	L	l	Tearing lead	cut	Max Torque Nm
IAACM3L1CZTC	M3	0,5 - 1,5	5	8	4,9	0,8	10	6	3900	900	2
IAACM3L2CZTC	M3	2 - 3,5	5	8	4,9	0,8	11,5	6	3900	900	2
IAACM4L1CZTC	M4	0,5 - 2	6	9	5,9	0,8	10,5	6	6800	1500	5
IAACM4L2CZTC	M4	2 - 3,5	6	9	5,9	0,8	12	6	6800	1500	5
IAACM5L1CZTC	M5	0,5 - 2,5	7	10	6,9	1	13	7,5	11500	2000	8,5
IAACM5L2CZTC	M5	2,5 - 5	7	10	6,9	1	16,5	8,5	11500	2000	8,5
IAACM6L1CZTC	M6	0,5 - 3	9	12.3(13.0)	8,9	1,3	15	9,2	16500	3000	15
IAACM6L2CZTC	M6	3 - 5,5	9	12.3(13.0)	8,9	1,3	19,5	10,5	16500	3000	15
IAACM8L1CZTC	M8	1 - 3,5	11	14.5(16.0)	10,9	1,5	18	11,5	25000	4400	26
IAACM8L2CZTC	M8	3,5 - 6	11	14.5(16.0)	10,9	1,5	21	11,5	25000	4400	26
IAACM10L1CZTC	M10	1 - 4	13	17.0(19.0)	12,9	1,7	21	13,5	32000	5000	50
IAACM10L2CZTC	M10	4 - 6,5	13	17.0(19.0)	12,9	1,7	24	13,5	32000	5000	50
IAACM12L1CZTC	M12	1 - 4	16	22	15,9	2	25	15	34000	6500	80

ZINC PLATED STEEL RIVET NUT CLOSED - KNURLED SHANK CYLINDRICAL HEAD

ICACM L1 CZTC
ICACM L2 CZTC

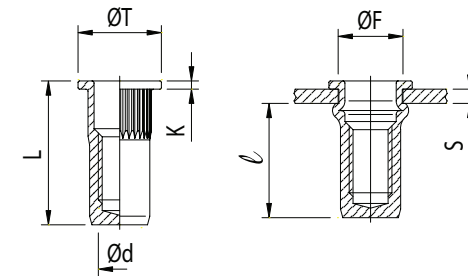

CODE	Thread Ød	S	ØF +0.10	Ø head (ØT)	Ø shank	K	L	ℓ	Tearing lead	cut	Max Torque Nm
ICACM4L1CZTC	M4	0,5 - 2	6	9	5,9	0,8	16	11,3	6800	1500	5
ICACM4L2CZTC	M4	2 - 4	6	9	5,9	0,8	18	11,3	6800	1500	5
ICACM5L1CZTC	M5	0,5 - 3	7	10	6,9	1	17	11,5	11500	2000	8,5
ICACM5L2CZTC	M5	2,5 - 5	7	10	6,9	1	19	11,5	11500	2000	8,5
ICACM6L1CZTC	M6	0,5 - 3	9	12,3	8,9	1,3	19,2	12,7	16500	3000	15
ICACM6L2CZTC	M6	3 - 5	9	12,3	8,9	1,3	21	12,7	16500	3000	15
ICACM8L1CZTC	M8	0,5 - 3	11	15	10,9	1,5	21,5	14,8	25000	4400	26
ICACM8L2CZTC	M8	3 - 5,5	11	15	10,9	1,5	24	14,8	25000	4400	26
ICACM10L1CZTC	M10	1 - 4	13	17	12,9	1,6	27	19,2	32000	5000	50
ICACM10L2CZTC	M10	3,5 - 6	13	17	12,9	1,6	32,5	22	32000	5000	50
ICACM12L1CZTC	M12	1 - 4	16	22	15,9	2	31	19,2	34000	6500	80
ICACM12L2CZTC	M12	3,5 - 6	16	22	15,9	2	33	22	34000	6500	80

ZINC PLATED STEEL RIVET NUT OPEN - KNURLED SHANK REDUCED HEAD

IAACM L1 CZTF
IAACM L2 CZTF

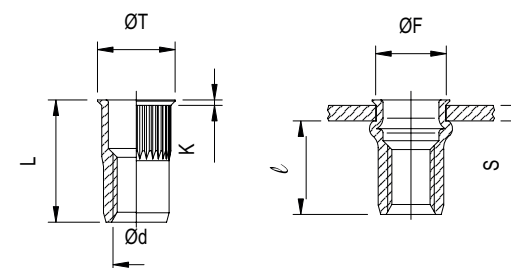

CODE	Thread Ød	S	ØF +0.10	Ø head (ØT)	Ø shank	K	L	ℓ	Tearing lead	cut	Max Torque Nm
IAACM3L1CZTF	M3	0,5 - 2	5	6	4,9	0,5	9	6,2	3900	900	1
IAACM3L2CZTF	M3	1,5 - 3	5	6	4,9	0,5	11,5	6,2	3900	900	1
IAACM4L1CZTF	M4	0,5 - 2	6	7	5,9	0,5	11,2	7	6800	1500	3
IAACM4L2CZTF	M4	2 - 4	6	7	5,9	0,5	13	7	6800	1500	3
IAACM5L1CZTF	M5	0,5 - 2	7	8	6,9	0,5	11,5	7	11500	2000	6
IAACM5L2CZTF	M5	2 - 4	7	8	6,9	0,5	13	7	11500	2000	6
IAACM6L1CZTF	M6	0,5 - 2,5	9	10	8,9	0,6	14	8,5	16500	3000	11
IAACM6L2CZTF	M6	2,5 - 5	9	10	8,9	0,6	16	8,5	16500	3000	11
IAACM8L1CZTF	M8	0,5 - 3	11	12	10,9	0,65	16,5	10	25000	4400	20
IAACM8L2CZTF	M8	3 - 5	11	12	10,9	0,65	18,5	10	25000	4400	20
IAACM10L1CZTF	M10	1 - 3,5	13	14,37	12,9	0,7	19,5	12,5	32000	5000	32
IAACM10L2CZTF	M10	3,5 - 6	13	14,37	12,9	0,7	22	12,5	32000	5000	32
IAACM12L1CZTF	M12	1 - 4	16	17,6	15,9	0,75	24,2	16,2	34000	6500	50
IAACM12L2CZTF	M12	4 - 6,5	16	17,6	15,9	0,8	27,5	16,2	34000	6500	50

ZINC PLATED STEEL RIVET NUT CLOSED - KNURLED SHANK REDUCED HEAD

ICACM L1 CZTF
ICACM L2 CZTF

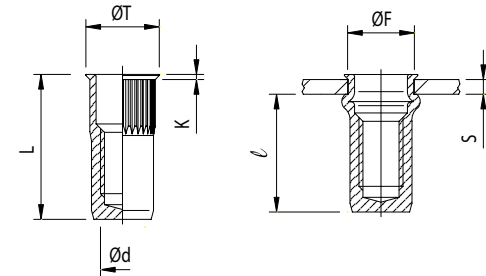

CODE	Thread Ød	S	ØF +0.10	Ø head (ØT)	Ø shank	K	L	ℓ	Tearing lead	cut	Max Torque Nm
ICACM3L1CZTF	M3	0,5 - 1,5	5	6	4,9	0,5	12,5	6,2	3900	900	1
ICACM4L1CZTF	M4	0,5 - 2	6	7	5,9	0,5	15	11	6800	1500	3
ICACM4L2CZTF	M4	2 - 3,5	6	7	5,9	0,5	16,5	11	6800	1500	3
ICACM5L1CZTF	M5	0,5 - 2	7	8	6,9	0,5	16,5	12,5	11500	2000	6
ICACM5L2CZTF	M5	2 - 3,5	7	8	6,9	0,5	18	12,5	11500	2000	6
ICACM6L1CZTF	M6	0,5 - 3	9	10	8,9	0,6	20,5	15,5	16500	3000	11
ICACM6L2CZTF	M6	3 - 4,5	9	10	8,9	0,6	22	15,5	16500	3000	11
ICACM8L1CZTF	M8	0,5 - 3	11	12	10,9	0,65	23	17	25000	4400	20
ICACM8L2CZTF	M8	3 - 4,5	11	12	10,9	0,65	24,5	17	25000	4400	20
ICACM10L1CZTF	M10	1 - 3	13	14	12,9	0,7	24,5	18,2	32000	5000	32
ICACM10L2CZTF	M10	3 - 5	13	14	12,9	0,7	26	18,2	32000	5000	32
ICACM12L1CZTF	M12	1 - 4	16	17,6	15,9	0,8	29	20	34000	6500	50
ICACM12L2CZTF	M12	3 - 6	16	17,6	15,9	0,8	32	20	34000	6500	50

ZINC PLATED STEEL RIVET NUT OPEN - KNURLED SHANK COUNTERSUNK HEAD

IAACM L1 CZTS
IAACM L2 CZTS

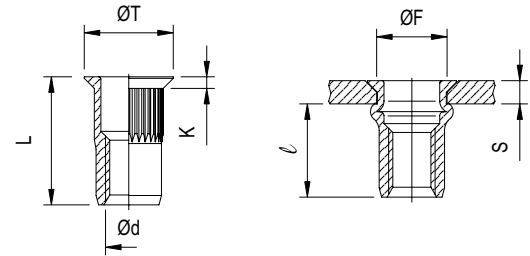

CODE	Thread Ød	S	ØF +0.10	Ø head (ØT)	Ø shank	K	L	ℓ	Tearing lead	cut	Max Torque Nm
IAACM3L1CZTS	M3	1,5 - 2,5	5	7,5	4,9	1,5	9,5	4,5	3900	900	1
IAACM3L2CZTS	M3	2,5 - 4	5	7,5	4,9	1,5	10,5	4,5	3900	900	1
IAACM4L1CZTS	M4	1,5 - 3	6	9	5,9	1,5	12	6,5	6800	1500	4
IAACM4L2CZTS	M4	3,5 - 5	6	9	5,9	1,5	13	6,5	6800	1500	4
IAACM5L1CZTS	M5	1,5 - 3,5	7	10	6,9	1,5	13	7,5	11500	2000	8
IAACM5L2CZTS	M5	3 - 5	7	10	6,9	1,5	15	7,5	11500	2000	8
IAACM6L1CZTS	M6	1,5 - 4	9	12	8,9	1,5	15,5	9	16500	3000	15
IAACM6L2CZTS	M6	4 - 6	9	12	8,9	1,5	17	9	16500	3000	15
IAACM8L1CZTS	M8	2 - 4,5	11	14	10,9	1,5	18,5	11	25000	4400	26
IAACM8L2CZTS	M8	4,5 - 6	11	14	10,9	1,5	21	11	25000	4400	26
IAACM10L1CZTS	M10	2 - 5	13	16	12,9	1,5	21	13	32000	5000	45
IAACM10L2CZTS	M10	3,5 - 6,5	13	16	12,9	1,5	24	13	32000	5000	45
IAACM12L1CZTS	M12	2 - 5	16	19	15,9	1,9	24	16,5	34000	6500	70
IAACM12L2CZTS	M12	5 - 7	16	19	15,9	1,8	27,5	16,5	34000	6500	70

ZINC PLATED STEEL RIVET NUT CLOSED - KNURLED SHANK COUNTERSUNK HEAD

ICACM L1 CZTS
ICACM L2 CZTS

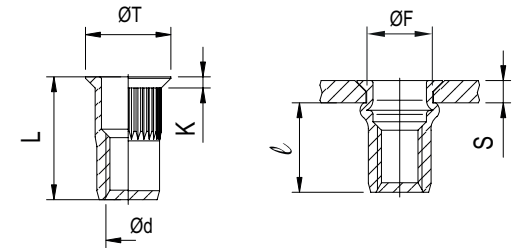

CODE	Thread Ød	S	ØF +0.10	Ø head (ØT)	Ø shank	K	L	ℓ	Tearing lead	cut	Max Torque Nm
ICACM3L1CZTS	M3	1,5 - 2,5	5	7,5	4,9	1,5	15,5	10,3	3900	900	1
ICACM3L2CZTS	M3	2,5 - 4	5	7,5	4,9	1,5	17,5	10,3	3900	900	1
ICACM4L1CZTS	M4	1,5 - 3	6	9	5,9	1,5	17,5	12,3	6800	1500	4
ICACM4L2CZTS	M4	3 - 5	6	9	5,9	1,5	19,5	12,3	6800	1500	4
ICACM5L1CZTS	M5	1,5 - 3,5	7	10	6,9	1,5	19,5	14	11500	2000	8
ICACM5L2CZTS	M5	3,5 - 5	7	10	6,9	1,5	23,5	14	11500	2000	8
ICACM6L1CZTS	M6	1,5 - 4	9	12	8,9	1,5	23,5	17,5	16500	3000	15
ICACM6L2CZTS	M6	4 - 6	9	12	8,9	1,5	25,5	17,5	16500	3000	15
ICACM8L1CZTS	M8	1,5 - 4,5	11	14	10,9	1,5	26,5	20	25000	4400	26
ICACM8L2CZTS	M8	4,5 - 6	11	14	10,9	1,5	29,5	20	25000	4400	26
ICACM10L1CZTS	M10	1,5 - 5	13	16	12,9	1,5	30	21,5	32000	5000	45
ICACM10L2CZTS	M10	4,5 - 6,5	13	16	12,9	1,5	32,5	21,5	32000	5000	45
ICACM12L1CZTS	M12	1,5 - 5,5	16	19	15,9	1,5	33	22,5	34000	6500	70
ICACM12L2CZTS	M12	5,5 - 7	16	19	15,9	1,5	35	22,5	34000	6500	70

ZINC PLATED STEEL RIVET NUT OPEN - SEMI-HEXAGONAL SHANK CYLINDRICAL HEAD

IAACM L1 SETC
IAACM L2 SETC

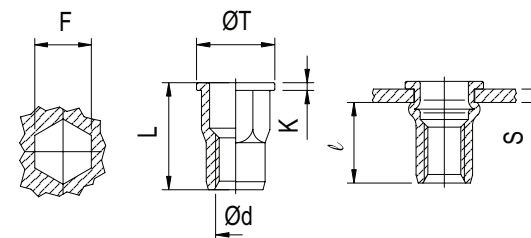

CODE	Thread Ød	S	ØF +0.10	Ø head (ØT)	Ø shank	K	L	ℓ	Tearing lead	cut	Max Torque Nm
IAACM3L1SETC	M3	0,5 - 1,5	5	8	4,9	0,75	9	5,5	3900	900	2
IAACM4L1SETC	M4	0,5 - 2	6	9	5,9	0,8	11,5	6	6000	2000	3
IAACM4L2SETC	M4	2 - 4	6	9	5,9	0,8	13	7	6800	1500	5
IAACM5L1SETC	M5	0,5 - 3	7	10	6,9	1	13,5	8	9000	3000	6
IAACM5L2SETC	M5	2,5 - 4	7	10	6,9	1	14	7,5	11500	2000	8,5
IAACM6L1SETC	M6	0,5 - 3	9	12	8,9	1,2	16	10	15000	4300	10
IAACM6L2SETC	M6	3 - 5	9	12,7	8,9	1,35	18	9,2	16500	3000	15
IAACM8L1SETC	M8	0,5 - 3,5	11	16	10,9	1,4	17,5	12	26000	5600	24
IAACM8L2SETC	M8	3,5 - 5,5	11	16	10,9	1,5	21	11,2	25000	4400	26
IAACM10L1SETC	M10	1 - 3,5	13	18	12,9	1,7	22	15	35000	6500	45
IAACM10L2SETC	M10	3,5 - 6	13	18	12,9	1,7	23	12,5	32000	5000	50
IAACM12L1SETC	M12	2 - 5	16	23	15,9	2,2	27,5	16,5	34000	6500	80

ZINC PLATED STEEL RIVET NUT OPEN - HEXAGONAL SHANK CYLINDRICAL HEAD

IAACM L1 TETC
IAACM L2 TETC

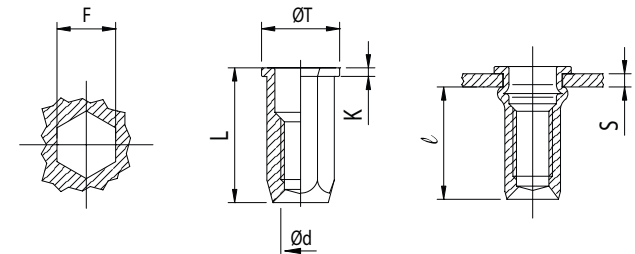

CODE	Thread Ød	S	ØF +0.10	Ø head (ØT)	Ø shank	K	L	ℓ	Tearing lead	cut	Max Torque Nm
IAACM3L1TETC	M3	0,5 - 1,5	5	7,5	4,9	0,8	8,5	5,5	3900	900	2
IAACM3L2TETC	M3	1,5 - 3	5	7,5	4,9	0,8	11	5,5	3900	900	2
IAACM4L1TETC	M4	0,5 - 2	6	9	5,9	0,8	11	6,5	6800	1500	5
IAACM4L2TETC	M4	2 - 4	6	9	5,9	0,8	13	6,5	6800	1500	5
IAACM5L1TETC	M5	0,5 - 2,5	7	10	6,9	1	14	8	11500	2000	8,5
IAACM5L2TETC	M5	2,5 - 5	7	10	6,9	1	16,5	8	11500	2000	8,5
IAACM6L1TETC	M6	0,5 - 3	9	12,70(*13,00)	8,9	1,35	15,00(*16,00)	8,5	16500	3000	15
IAACM6L2TETC	M6	3 - 5,5	9	12,70(*13,00)	8,9	1,35	19,5	8,5	16500	3000	15
IAACM8L1TETC	M8	1 - 3,5	11	16	10,9	1,5	18	10,5	25000	4400	26
IAACM8L2TETC	M8	3,5 - 5,5	11	16	10,9	1,5	21	10,5	25000	4400	26
IAACM10L1TETC	M10	1 - 3,5	13	18,00(*19,00)	12,9	1,7	21,00(*23,00)	12,5	32000	5000	50
IAACM10L2TETC	M10	3,5 - 6	13	19	12,9	1,7	24	12,5	32000	5000	50
IAACM12L1TETC	M12	2 - 5	16	23	15,9	2	27	16,5	34000	6500	80
IAACM12L2TETC	M12	5 - 8	16	23	15,9	2	30	16,5	34000	6500	80

ZINC PLATED STEEL RIVET NUT CLOSED - HEXAGONAL SHANK CYLINDRICAL HEAD

ICACM L1 TETC
ICACM L2 TETC

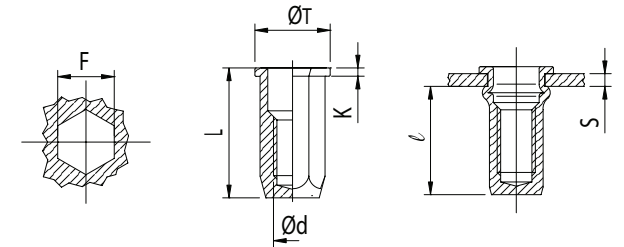

CODE	Thread Ød	S	ØF +0.10	Ø head (ØT)	Ø shank	K	L	ℓ	Tearing lead	cut	Max Torque Nm
ICACM4L1TETC	M4	0,5 - 2	6	9	5,9	1	15	11	6800	1500	5
ICACM4L2TETC	M4	2 - 4	6	9	5,9	1	17	11	6800	1500	5
ICACM5L1TETC	M5	0,5 - 2,5	7	10	6,9	1	18	13,5	11500	2000	8,5
ICACM5L2TETC	M5	2,5 - 5	7	10	6,9	1	20	13,5	11500	2000	8,5
ICACM6L1TETC	M6	0,5 - 3	9	12,7	8,9	1,5	23	17	16500	3000	15
ICACM6L2TETC	M6	3 - 5,5	9	12,7	8,9	1,5	25	17	16500	3000	15
ICACM8L1TETC	M8	1 - 3,5	11	16	10,9	1,5	26	19	25000	4400	26
ICACM8L2TETC	M8	3,5 - 5,5	11	16	10,9	1,5	29	19	25000	4400	26
ICACM10L1TETC	M10	1 - 4	13	19	12,9	2	33	25	32000	5000	50
ICACM10L2TETC	M10	4 - 6	13	19	12,9	1,8	35	25	32000	5000	50
ICACM12L1TETC	M12	2 - 5	16	23	15,9	2	35	25	34000	6500	80
ICACM12L2TETC	M12	5 - 8	16	23	15,9	2	38	25	34000	6500	80

ZINC PLATED STEEL RIVET NUT OPEN - HEXAGONAL SHANK REDUCED HEAD

IAACM L1 TETF
IAACM L2 TETF

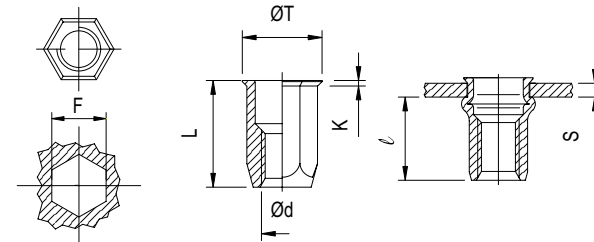

CODE	Thread Ød	S	ØF +0.10	Ø head (ØT)	Ø shank	K	L	l	Tearing lead	cut	Max Torque Nm
IAACM3L1TETF	M3	0,5 - 1,5	5	6	4,9	0,5	8,5	6	3900	900	1
IAACM3L2TETF	M3	1,5 - 3	5	6	4,9	0,5	10,5	6	3900	900	1
IAACM4L1TETF	M4	0,5 - 2,5	6	7	5,9	0,5	11	6,7	6800	1500	3
IAACM4L2TETF	M4	2,5 - 5	6	7	5,9	0,5	13,5	6,7	6800	1500	3
IAACM5L1TETF	M5	0,5 - 3	7	8	6,9	0,5	14	8	9000		6
IAACM5L2TETF	M5	3 - 5	7	8	6,9	0,5	16	9	11500	2000	6
IAACM6L1TETF	M6	0,5 - 3	9	10	8,9	0,6	16.00 (15)	10	15000		10
IAACM6L2TETF	M6	3,5 - 6	9	10	8,9	0,6	18	10	16500	3000	11
IAACM8L1TETF	M8	0,5 - 3,5	11	12	10,9	0,7	18	12	26000		24
IAACM8L2TETF	M8	4 - 6	11	12	10,9	0,65	20	11,5	25000	4400	20
IAACM10L1TETF	M10	1 - 3,5	13	14,5	12,9	0,75	19	12,5	32000	5000	32
IAACM10L2TETF	M10	3,5 - 6	13	15,5	12,9	0,75	23,5	14,5	32000	5000	32
IAACM12L1TETF	M12	1 - 4	16	17,5	15,9	1,1	25	15,5	34000	6500	50
IAACM12L2TETF	M12	4 - 7	16	17,5	15,9	1,1	28	15,5	34000	6500	50

ZINC PLATED STEEL RIVET NUT CLOSED - HEXAGONAL SHANK REDUCED HEAD

ICACM L1 TETF
ICACM L2 TETF

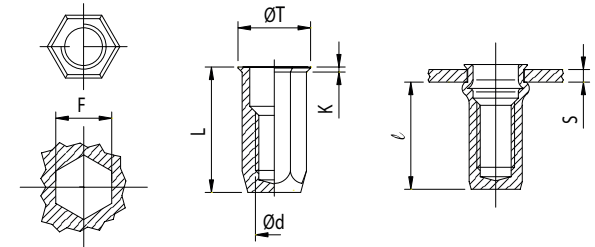

CODE	Thread Ød	S	ØF +0.10	Ø head (ØT)	Ø shank	K	L	ℓ	Tearing lead	cut	Max Torque Nm
ICACM4L1TETF	M4	0,5 - 2,5	6	7	5,9	0,5	16	12,3	6800	1500	3
ICACM4L2TETF	M4	2,5 - 4	6	7	5,9	0,5	18	12,3	6800	1500	3
ICACM5L1TETF	M5	0,5 - 3	7	8	6,9	0,5	20	15,2	11500	2000	6
ICACM5L2TETF	M5	3 - 5	7	8	6,9	0,5	23	15,2	11500	2000	6
ICACM6L1TETF	M6	0,5 - 3,5	9	10	8,9	0,6	20,5	14,5	16500	3000	11
ICACM6L2TETF	M6	3,5 - 5,5	9	10	8,9	0,6	23,5	14,5	16500	3000	11
ICACM8L1TETF	M8	1 - 4	11	12	10,9	0,65	23	17	25000	4400	20
ICACM8L2TETF	M8	4 - 6	11	12	10,9	0,65	25	17	25000	4400	20
ICACM10L1TETF	M10	1 - 4,5	13	14,5	12,9	0,75	28,5	20	32000	5000	32
ICACM10L2TETF	M10	4 - 6	13	14,5	12,9	0,8	30,5	20	32000	5000	32
ICACM12L1TETF	M12	1 - 4	16	14,5	15,9	0,75	34	20	34000	6500	50
ICACM12L2TETF	M12	4 - 7	16	14,5	15,9	0,8	36	20	34000	6500	50

ZINC PLATED STEEL RIVET NUT OPEN - SEMI-HEXAGONAL SHANK REDUCED HEAD

IAACM L1 SETFE
IAACM L2 SETFE

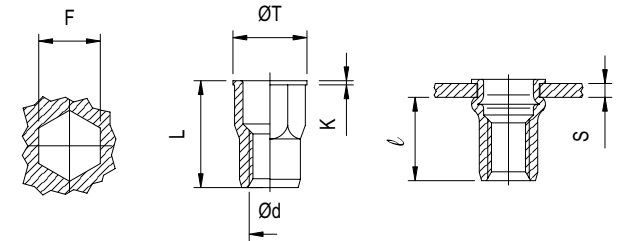

CODE	Thread Ød	S	ØF +0.10	Ø head (ØT)	Ø shank	K	L	l	Tearing lead	cut	Max Torque Nm
IAACM3L1SETFE	M3	0,5 - 1,5	5	6	4,9	0,5	8,5	5,5	3900	900	1
IAACM3L2SETFE	M3	1,5 - 2,5	5	6	4,9	0,5	10,5	5,5	3900	900	1
IAACM4L1SETFE	M4	0,5 - 2	6	7	5,9	0,5	12	8,3	6800	1500	3
IAACM4L2SETFE	M4	2 - 4	6	7	5,9	0,5	14	8,3	6800	1500	3
IAACM5L1SETFE	M5	0,5 - 2,5	7	8	6,9	0,5	13	8,7	11500	2000	6
IAACM5L2SETFE	M5	2,5 - 4,5	7	8	6,9	0,5	15	8,7	15000	2000	6
IAACM6L1SETFE	M5	1 - 3,5	9	10	8,9	0,6	16	10,5	16500	3000	11
IAACM6L2SETFE	M5	3,5 - 5	9	10	8,9	0,6	18	10,5	16500	3000	11
IAACM8L1SETFE	M5	1 - 3,5	11	12	10,9	0,65	17,5	11,3	25000	4400	20
IAACM8L2SETFE	M5	3,5 - 6	11	12	10,9	0,65	20	11,3	25000	4400	20
IAACM10L1SETFE	M10	1 - 4	13	14,5	12,9	0,75	21	12,8	32000	5000	32
IAACM10L2SETFE	M10	4 - 6	13	14,5	12,9	0,75	23	12,8	32000	5000	32
IAACM12L1SETFE	M12	1 - 4	16	17,5	15,9	1	24	14,8	34000	6500	50
IAACM12L2SETFE	M12	4 - 7	16	17,5	15,9	1	28	14,8	34000	6500	50

ZINC PLATED STEEL RIVET NUT CLOSED - SEMI-HEXAGONAL REDUCED HEAD

ICACM L1 SETFE
ICACM L2 SETFE

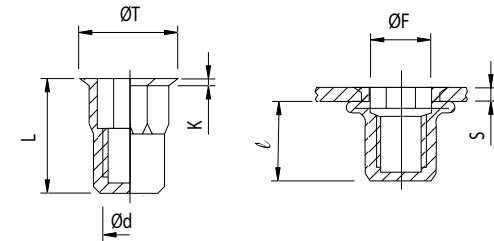

CODE	Thread Ød	S	ØF +0.10	Ø head (ØT)	Ø shank	K	L	ℓ	Tearing lead	cut	Max Torque Nm
ICACM4L1SETFE	M4	0,5 - 2	6	7	5,9	0,6	15,5	11,5	6800	1500	3
ICACM4L2SETFE	M4	2 - 4	6	7	5,9	0,6	18	11,5	6800	1500	3
ICACM5L1SETFE	M5	0,5 - 2,5	7	8	6,9	0,6	18	13,5	11500	2000	6
ICACM5L2SETFE	M5	2,5 - 4,5	7	8	6,9	0,6	23	13,5	11500	2000	6
ICACM6L1SETFE	M6	1 - 3,5	9	10	8,9	0,6	21,5	15,8	16500	3000	11
ICACM6L2SETFE	M6	3 - 5	9	10	8,9	0,6	23,5	15,8	16500	3000	11
ICACM8L1SETFE	M8	1 - 3,5	11	12	10,9	0,7	24	18,2	25000	4400	20
ICACM8L2SETFE	M8	3,5 - 5,5	11	12	10,9	0,7	25	18,2	25000	4400	20
ICACM10L1SETFE	M10	1 - 4	13	14,5	12,9	0,85	30,5	23,2	32000	5000	32
ICACM10L2SETFE	M10	4 - 6	13	14,5	12,9	0,85	35	23,2	32000	5000	32
ICACM12L1SETFE	M12	1 - 4	16	17,5	15,9	1	32,5	22,5	34000	6500	50
ICACM12L2SETFE	M12	4 - 7	16	17,5	15,9	1	35	22,5	34000	6500	50

ZINC PLATED STEEL RIVET NUT OPEN - SEMI-HEXAGONAL SHANK REDUCED CYLINDRICAL HEAD

IAACM L1 SETFC
IAACM L2 SETFC

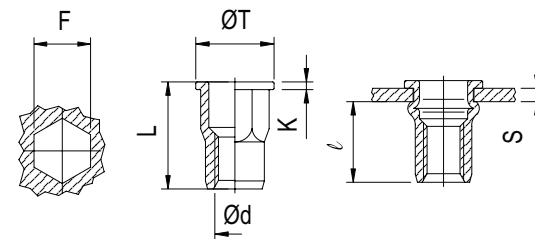

CODE	Thread Ød	S	ØF +0.10	Ø head (ØT)	Ø shank	K	L	ℓ	Tearing lead	cut	Max Torque Nm
IAACM4L1SETFC	M4	0,5 - 2	6	7,2	5,9	0,5	11,2	6	6000		3
IAACM5L1SETFC	M5	0,5 - 3	7	8,2	6,9	0,5	13,3	8	9000		6
IAACM5L2SETFC	M5	2 - 5,5	7	8,2	6,9	0,5	15,8	8			
IAACM6L1SETFC	M6	0,5 - 3	9	10,5	8,9	0,6	15,3	10	15000		10
IAACM6L2SETFC	M6	2 - 5,5	9	10,5	8,9	0,6	17,8	10			
IAACM8L1SETFC	M8	0,5 - 3,5	11	13	10,9	0,7	16,7	12	26000		24
IAACM8L2SETFC	M8	2,5 - 6,5	11	13	10,9	0,7	19,7	12			
IAACM10L1SETFC	M10	1 - 3,5	13	15		0,8	21	15	35000		45

STAINLESS STEEL A2 RIVET NUT OPEN - FLAT SHANK CYLINDRICAL HEAD

IAA2M L1 CLTC

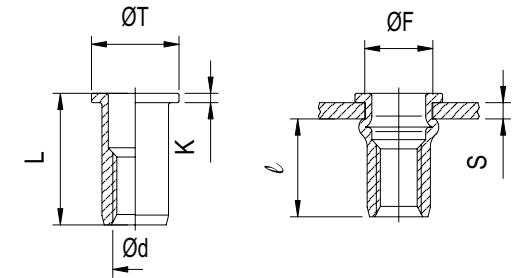

CODE	Thread Ød	S	ØF +0.10	Ø head (ØT)	Ø shank	K	L	ℓ	Tearing lead	cut	Max Torque Nm
IAA2M4L1CLTC	M4	0,5 - 2	6	8,5	5,9	0,8	10,5	6	6800	1500	5
IAA2M5L1CLTC	M5	0,5 - 2,5	7	10	6,9	1	13	7,5	11500	2000	8,5
IAA2M6L1CLTC	M6	0,5 - 3	9	12,3	8,9	1,3	15,5	9,2	16500	3000	15
IAA2M8L1CLTC	M8	1 - 3,5	11	15	10,9	1,5	18,5	11,5	25000	4400	26
IAA2M10L1CLTC	M10	1 - 4	13	17	12,9	1,6	21	12,5	32000	5000	50

STAINLESS STEEL A2 RIVET NUT CLOSED - FLAT SHANK CYLINDRICAL HEAD

ICA2M L1 CLTC

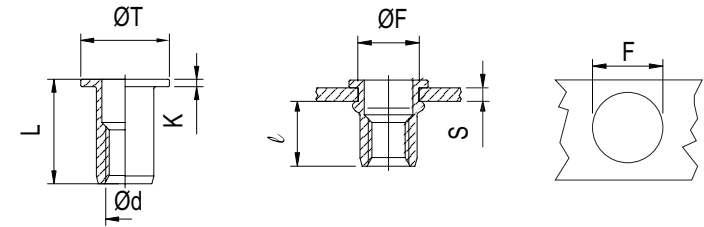

CODE	Thread Ød	S	ØF +0.10	Ø head (ØT)	Ø shank	K	L	l	Tearing lead	cut	Max Torque Nm
ICA2M4L1CLTC	M4	0,5 - 2	6	9	5,9	0,8	16	11,3	6800	1500	5
ICA2M5L1CLTC	M5	0,5 - 2,5	7	10	6,9	1	19	13,8	11500	2000	8,5
ICA2M6L1CLTC	M6	0,5 - 3	9	12,3	8,9	1,3	21	15	16500	3000	15
ICA2M8L1CLTC	M8	1 - 3,5	11	15,5	10,9	1,5	25	18,2	25000	4400	26
ICA2M10L1CLTC	M10	1 - 4	13	17	12,9	1,6	27	19,4	32000	5000	50

STAINLESS STEEL A2 RIVET NUT OPEN - FLAT SHANK REDUCED HEAD

IAA2M L1 CLTF

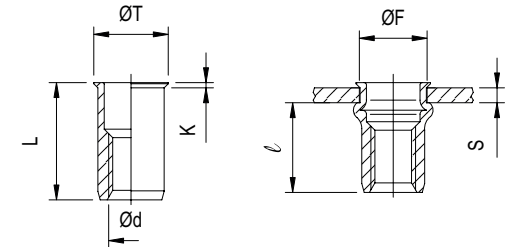

CODE	Thread $\varnothing d$	S	$\varnothing F$ +0.10	\varnothing head ($\varnothing T$)	\varnothing shank	K	L	ℓ	Tearing lead	cut	Max Torque Nm
IAA2M3L1CLTF	M3	0,5 - 1,5	5	6	4,9	0,5	9	5	3900	900	1
IAA2M4L1CLTF	M4	0,5 - 2	6	7	5,9	0,5	10,5	6,5	6800	1500	3
IAA2M5L1CLTF	M5	0,5 - 2	7	8	6,9	0,5	11,5	7	11500	2000	6
IAA2M6L1CLTF	M6	0,5 - 2,5	9	10	8,9	0,6	14	8,5	16500	3000	11
IAA2M8L1CLTF	M8	0,5 - 3	11	12	10,9	0,65	16,5	10,5	25000	4400	20
IAA2M10L1CLTF	M10	1 - 3	13	14	12,9	0,7	17,7	11,5	32000	5000	32

STAINLESS STEEL A2 RIVET NUT CLOSED - KNURLED SHANK REDUCED HEAD

ICA2M L1 CLTF

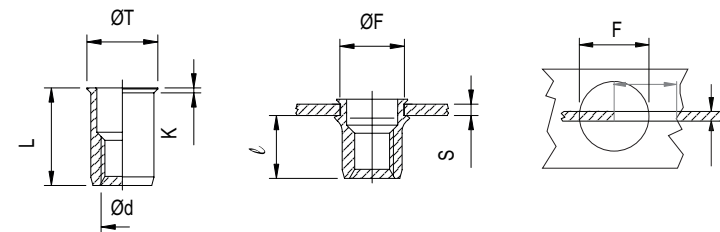

CODE	Thread Ød	S	ØF +0.10	Ø head (ØT)	Ø shank	K	L	l	Tearing lead	cut	Max Torque Nm
ICA2M3L1CLTF	M3	0,5 - 1,5	5	6	4,9	0,5	13	9	3900	900	1
ICA2M4L1CLTF	M4	0,5 - 2	6	7	5,9	0,5	15	11	6800	1500	3
ICA2M5L1CLTF	M5	0,5 - 2	7	8	6,9	0,5	16,5	12,5	11500	2000	6
ICA2M6L1CLTF	M6	0,5 - 2,5	9	10	8,9	0,6	20,5	15,5	16500	3000	11
ICA2M8L1CLTF	M8	0,5 - 3	11	12	10,9	0,65	23	17,6	25000	4400	20
ICA2M10L1CLTF	M10	1 - 3,5	13	14	12,9	0,7	24,5	18,3	32000	5000	32

STAINLESS STEEL A2 RIVET NUT OPEN - KNURLED SHANK CYLINDRICAL HEAD

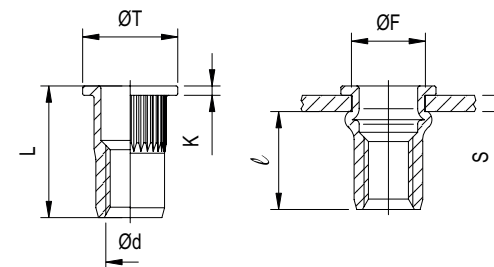
 IAA2M L1 CZTC
 IAA2M L2 CZTC

CODE	Thread Ød	S	ØF +0.10	Ø head (ØT)	Ø shank	K	L	ℓ	Tearing lead	cut	Max Torque Nm
IAA2M3L1CZTC	M3	0,5 - 1,5	5	7	4,9	0,8	9	5	3900	900	2
IAA2M3L2CZTC	M3	1,5 - 2	5	7	4,9	0,8	11	5	3900	900	2
IAA2M4L1CZTC	M4	0,5 - 2	6	9	5,9	0,8	11,5	6	9000	3500	7
IAA2M4L2CZTC	M4	2 - 4	6	9	5,9	0,8	12	6,5	6800	1500	5
IAA2M5L1CZTC	M5	0,5 - 3	7	10	6,9	1	13,5	8	12000	5500	11
IAA2M5L2CZTC	M5	2 - 4	7	10	6,9	1	15	8	11500	2000	8,5
IAA2M6L1CZTC	M6	0,5 - 3	9	12	8,9	1,2	16	10	23000	8000	21
IAA2M6L2CZTC	M6	2 - 5,5	9	12	0	1,2	18,5	10			
IAA2M8L1CZTC	M8	0,5 - 3,5	11	15	10,9	1,4	17,5	12	30000	11000	35
IAA2M8L2CZTC	M8	3,5 - 5,5	11	14,5(16)	10,9	1,5	21,5	11,5	25000	4400	26
IAA2M10L1CZTC	M10	1 - 3,5	13	17	12,9	2	22	15	38000	15000	40
IAA2M10L2CZTC	M10	4 - 6	13	17	12,9	1,7	24	13,5	32000	5000	50
IAA2M12L1CZTC	M12	1 - 4	16	23	15,9	2	23	15	34000	6500	80
IAA2M12L2CZTC	M12	4 - 6	16	23	15,9	2	26	16	34000	6500	80

STAINLESS STEEL A2 RIVET NUT CLOSED - KNURLED SHANK CYLINDRICAL HEAD

ICA2M L1 CZTC
ICA2M L2 CZTC

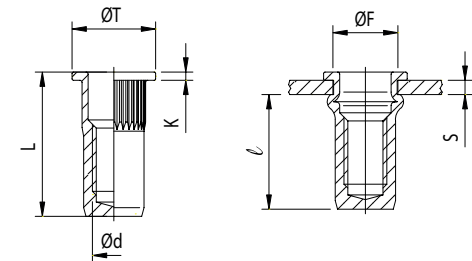

CODE	Thread Ød	S	ØF +0.10	Ø head (ØT)	Ø shank	K	L	ℓ	Tearing lead	cut	Max Torque Nm
ICA2M3L1CZTC	M3	0,5 - 1,5	5	7	4,9	0,8	13	8	3900	900	2
ICA2M3L2CZTC	M3	1,5 - 2,5	5	7	4,9	0,8	14	8	3900	900	2
ICA2M4L1CZTC	M4	0,5 - 2	6	9	5,9	0,8	14,5	11,8	6800	1500	5
ICA2M4L2CZTC	M4	2 - 4	6	9	5,9	0,8	18	11,8	6800	1500	5
ICA2M5L1CZTC	M5	0,5 - 2,5	7	10	6,9	1	17	12	11500	2000	8,5
ICA2M5L2CZTC	M5	2 - 4	7	10	6,9	1	19	12	11500	2000	8,5
ICA2M6L1CZTC	M6	0,5 - 3	9	12,3	8,9	1,3	19,2	12,7	16500	3000	15
ICA2M6L2CZTC	M6	3 - 5	9	12,3	8,9	1,3	21	12,7	16500	3000	15
ICA2M8L1CZTC	M8	1 - 3,5	11	14.50(15.00)	10,9	1,5	21,5	14,2	25000	4400	26
ICA2M8L2CZTC	M8	3,5 - 5,5	11	14.50(15.00)	10,9	1,5	24	14,8	25000	4400	26
ICA2M10L1CZTC	M10	1 - 4	13	17	12,9	1,6	27	18	32000	5000	50
ICA2M10L2CZTC	M10	4 - 6	13	17	12,9	1,7	30	19,2	32000	5000	50
ICA2M12L1CZTC	M12	1 - 4	16	23	15,9	1,8	31	29,5	34000	6500	80
ICA2M12L2CZTC	M12	4 - 6	16	23	15,9	2	33	29,5	34000	6500	80

STAINLESS STEEL A2 RIVET NUT OPEN - KNURLED SHANK REDUCED HEAD

IAA2M L1 CZTF
IAA2M L2 CZTF

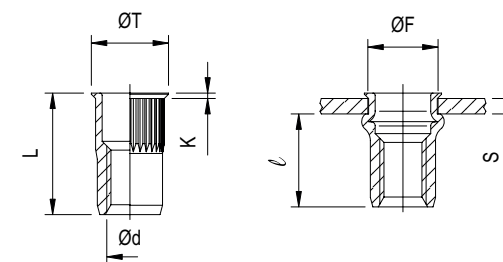

CODE	Thread Ød	S	ØF +0.10	Ø head (ØT)	Ø shank	K	L	l	Tearing lead	cut	Max Torque Nm
IAA2M3L1CZTF	M3	0,5 - 1,5	5	6	4,9	0,5	9	5	3900	900	1
IAA2M3L2CZTF	M3	1,5 - 2,5	5	6	4,9	0,5	11	6,2	3900	900	1
IAA2M4L1CZTF	M4	0,5 - 2	6	6,7	5,9	0,5	11,2	6	9000		7
IAA2M4L2CZTF	M4	2 - 4	6	7	5,9	0,5	13	7	6800	1500	3
IAA2M5L1CZTF	M5	0,5 - 3	7	8	6,9	0,5	13,3	8	12000		11
IAA2M5L2CZTF	M5	2 - 4	7	8	6,9	0,5	13	7,2	11500	2000	6
IAA2M6L1CZTF	M6	0,5 - 3	9	10	8,9	0,6	15,5	10	23000		21
IAA2M6L2CZTF	M6	2 - 5,5	9	10	8,9	0,6	18	10			
IAA2M8L1CZTF	M8	0,5 - 3,5	11	12	10,9	0,6	16,7	12	30000		35
IAA2M8L2CZTF	M8	3 - 5	11	12	10,9	0,65	19,5	10,5	25000	4400	20
IAA2M10L1CZTF	M10	1 - 3,5	13	14	12,9	0,7	21	15	38000		50
IAA2M10L2CZTF	M10	3,5 - 6	13	14	12,9	0,75	23	12,5	32000	5000	32
IAA2M12L1CZTF	M12	1 - 4	16	17,6	15,9	0,8	24,2	16,2	34000	6500	50
IAA2M12L2CZTF	M12	4 - 6,5	0	17,6	15,9	0,8	27	16,2	34000	6500	50

STAINLESS STEEL A2 RIVET NUT CLOSED - KNURLED SHANK REDUCED HEAD

ICA2M L1 CZTF
ICA2M L2 CZTF

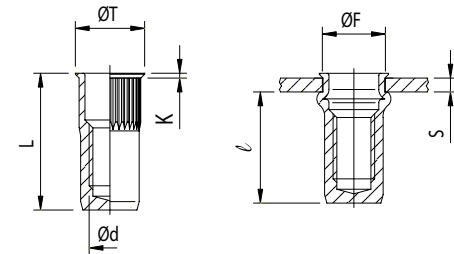

CODE	Thread $\varnothing d$	S	$\varnothing F$ +0.10	\varnothing head ($\varnothing T$)	\varnothing shank	K	L	l	Tearing lead	cut	Max Torque Nm
ICA2M3L1CZTF	M3	0,5 - 1,5	5	6	4,9	0,5	13	8,5	3900	900	1
ICA2M3L2CZTF	M3	1,5 - 2,5	5	6	4,9	0,5	14	8,5	3900	900	1
ICA2M4L1CZTF	M4	0,5 - 2	6	7	5,9	0,5	15	11,2	6800	1500	3
ICA2M4L2CZTF	M4	2 - 4	6	7	5,9	0,5	16,5	11,2	6800	1500	3
ICA2M5L1CZTF	M5	0,5 - 2	7	8	6,9	0,5	16,5	11,5	11500	2000	6
ICA2M5L2CZTF	M5	2 - 4	7	8	6,9	0,5	18	11,5	11500	2000	6
ICA2M6L1CZTF	M6	0,5 - 2,5	9	10	8,9	0,6	20,5	15	16500	3000	11
ICA2M6L2CZTF	M6	2,5 - 4,5	9	10	8,9	0,6	22	15	16500	3000	11
ICA2M8L1CZTF	M8	0,5 - 3	11	12	10,9	0,65	23	17,5	25000	4400	20
ICA2M8L2CZTF	M8	3 - 5	11	12	10,9	0,7	24,5	17,5	25000	4400	20
ICA2M10L1CZTF	M10	1 - 3,5	13	14	12,9	0,7	24,5	18	32000	5000	32
ICA2M10L2CZTF	M10	3,5 - 5,5	13	14	12,9	0,8	26	18	32000	5000	32
ICA2M12L1CZTF	M12	1 - 4	16	17,6	15,9	1	31,5	22	34000	6500	50

STAINLESS STEEL A2 RIVET NUT OPEN - FLAT SHANK COUNTERSUNK HEAD

IAA2M L1 CLTS

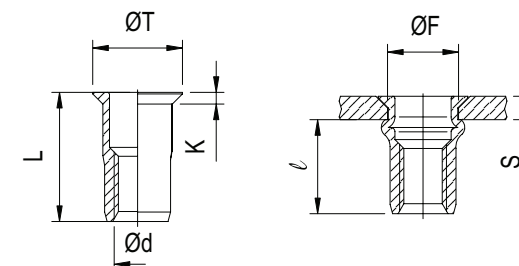

CODE	Thread Ød	S	ØF +0.10	Ø head (ØT)	Ø shank	K	L	l	Tearing lead	cut	Max Torque Nm
IAA2M4L1CLTS	M4	1,5 - 3	6	9	5,9	1,5	12	7,5	6800	1500	4
IAA2M5L1CLTS	M5	1,5 - 3,5	7	10	6,9	1,5	13	7,8	11500	2000	8
IAA2M6L1CLTS	M6	1,5 - 4	9	12	8,9	1,5	15,5	9	16500	3000	15
IAA2M8L1CLTS	M8	2 - 4,5	11	14	10,9	1,5	18,5	12	25000	4400	26
IAA2M10L1CLTS	M10	2 - 5	13	16	12,9	1,5	21	13	32000	5000	45

STAINLESS STEEL A2 RIVET NUT CLOSED - KNURLED SHANK REDUCED HEAD

ICA2M L1 CLTS

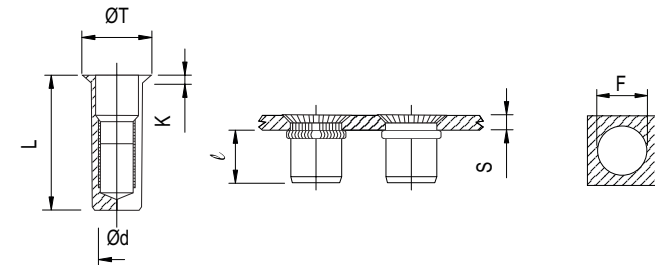

CODE	Thread Ød	S	ØF +0.10	Ø head (ØT)	Ø shank	K	L	ℓ	Tearing lead	cut	Max Torque Nm
ICA2M4L1CLTS	M4	1,6 - 3,5	6	9	5,9	1,5	17,3	12,3	6800	1500	4
ICA2M5L1CLTS	M5	1,6 - 3,5	7	10	6,9	1,5	19,5	13,5	11500	2000	8
ICA2M6L1CLTS	M6	1,6 - 4	9	12	8,9	1,5	23,5	17,5	16500	3000	15
ICA2M8L1CLTS	M8	1,6 - 4,5	11	14	10,9	1,5	26,5	20	25000	4400	26
ICA2M10L1CLTS	M10	1,6 4,5	13	16	12,9	1,7	33	25,5	32000	5000	45
ICA2M12L1CLTS	M12	1,6 4,5	15	19	14,9	1,8	38	31	34000	6500	70

STAINLESS STEEL A2 RIVET NUT OPEN - KNURLED SHANK COUNTERSUNK HEAD

IAA2M L1 CZTS
IAA2M L2 CZTS

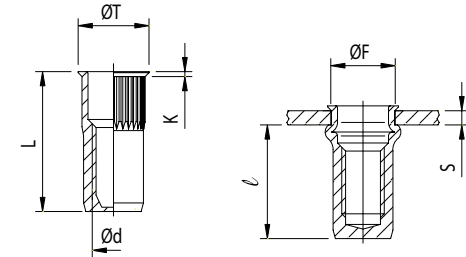

CODE	Thread Ød	S	ØF +0.10	Ø head (ØT)	Ø shank	K	L	ℓ	Tearing lead	cut	Max Torque Nm
IAA2M3L1CZTS	M3	1,5 - 2,5	5	7,5	4,9	1,5	8,5	4,5	3900	900	1
IAA2M3L2CZTS	M3	2,5 - 3,5	5	7,5	4,9	1,5	11,5	4,5	3900	900	1
IAA2M4L1CZTS	M4	1,5 - 3	6	9	5,9	1,5	12	7,5	6800	1500	4
IAA2M4L2CZTS	M4	3 - 5	6	9	5,9	1,5	13	7,5	6800	1500	4
IAA2M5L1CZTS	M5	1,5 - 3,5	7	10	6,9	1,5	13	7,8	11500	2000	8
IAA2M5L2CZTS	M5	3 - 5	7	10	6,9	1,5	15	7,8	11500	2000	8
IAA2M6L1CZTS	M6	1,5 - 4	9	12	8,9	1,5	15,5	9	16500	3000	15
IAA2M6L2CZTS	M6	4 - 6	9	12	8,9	1,5	19	9	16500	3000	15
IAA2M8L1CZTS	M8	2 - 4,5	11	14	10,9	1,5	18,5	12	25000	4400	26
IAA2M8L2CZTS	M8	4,5 - 6,5	11	14	10,9	1,5	21	12	25000	4400	26
IAA2M10L1CZTS	M10	2 - 5	13	16	12,9	1,5	21	13	32000	5000	45
IAA2M10L2CZTS	M10	4,5 - 6,5	13	16	12,9	1,5	24	13	32000	5000	45
IAA2M12L1CZTS	M12	2 - 5	16	18	15,9	1,7	24	17,5	34000	6500	70

STAINLESS STEEL A2 RIVET NUT CLOSED - FLAT SHANK COUNTERSUNK HEAD

ICA2M L1 CZTS

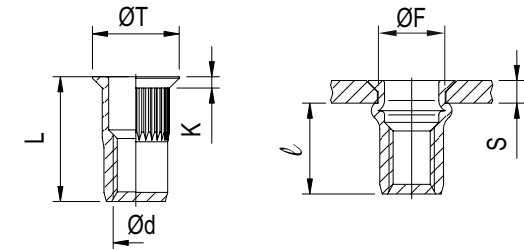

CODE	Thread Ød	S	ØF +0.10	Ø head (ØT)	Ø shank	K	L	ℓ	Tearing lead	cut	Max Torque Nm
ICA2M4L1CZTS	M4	1,6 - 3,5	6	9	5,9	1,5	17,3	12,3	6800	1500	4
ICA2M5L1CZTS	M5	1,6 - 3,5	7	10	6,9	1,5	19,5	13,5	11500	2000	8
ICA2M6L1CZTS	M6	1,6 - 4	9	12	8,9	1,5	23,5	17,5	16500	3000	15
ICA2M8L1CZTS	M8	1,6 - 4,5	11	14	10,9	1,5	26,5	20	25000	4400	26
ICA2M10L1CZTS	M10	1,6 - 4,5	13	16	12,9	1,7	33	25,5	32000	5000	45
ICA2M12L1CZTS	M12	1,6 - 4,5	15	19	14,9	1,8	38	31	34000	6500	70

STAINLESS STEEL A2 RIVET NUT OPEN - SEMI-HEXAGONAL CYLINDRICAL HEAD

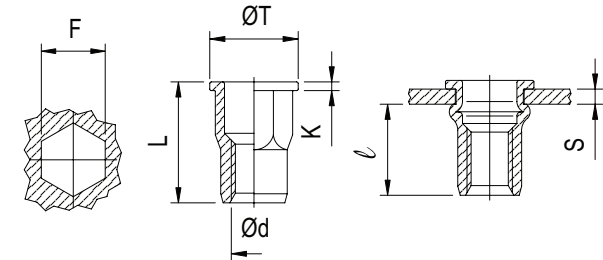
 IAA2M L1 SETC
 IAA2M L2 SETC

CODE	Thread Ød	S	ØF +0.10	Ø head (ØT)	Ø shank	K	L	ℓ	Tearing lead	cut	Max Torque Nm
IAA2M3L1SETC	M3	0,5 - 1,5	5	7	4,9	0,8	9	5	3900	900	2
IAA2M3L2SETC	M3	1,5 - 2,5	5	7	4,9	0,8	10	5	3900	900	2
IAA2M4L1SETC	M4	0,5 - 2	6	9	5,9	0,8	11,5	6	9000	3500	7
IAA2M4L2SETC	M4	2 - 4	6	9	5,9	0,8	13	7,2	6800	1500	5
IAA2M5L1SETC	M5	0,5 - 3	7	10	6,9	1	13,5	8	12000	5500	11
IAA2M5L2SETC	M5	2 - 4	7	10	6,9	1	14	7,5	11500	2000	8,5
IAA2M6L1SETC	M6	0,5 - 3	9	12	8,9	1,2	16	10	23000	8000	21
IAA2M6L2SETC	M6	3 - 5	9	12,7	8,9	1,3	19,5	9,2	16500	3000	15
IAA2M8L1SETC	M8	0,5 - 3,5	11	15	10,9	1,4	17,5	12	30000	11000	35
IAA2M8L2SETC	M8	3,5 - 5,5	11	16	10,9	1,5	21	11	25000	4400	26
IAA2M10L1SETC	M10	1 - 3,5	13	18	12,9	1,7	22	15	38000	15000	50
IAA2M10L2SETC	M10	4 - 6	13	18	12,9	1,7	24	13,2	32000	5000	50
IAA2M12L1SETC	M12	1 - 4	16	23	15,9	2	28	16	34000	6500	80
IAA2M12L2SETC	M12	6 - 8	16	23	15,9	2	30	16	34000	6500	80

STAINLESS STEEL A2 RIVET NUT CLOSED - SEMI-HEXAGONAL CYLINDRICAL HEAD

ICA2M L1 SETC
ICA2M L2 SETC

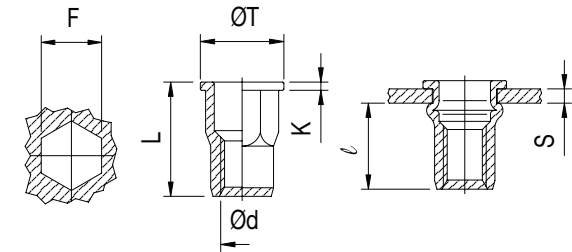

CODE	Thread $\varnothing d$	S	$\varnothing F$ +0.10	\varnothing head ($\varnothing T$)	\varnothing shank	K	L	l	Tearing lead	cut	Max Torque Nm
ICA2M4L1SETC	M4	0,5 - 2	6	9	5,9	1	16	11,5	6800	1500	5
ICA2M4L2SETC	M4	2 - 4	6	9	5,9	1	18	11,5	6800	1500	5
ICA2M5L1SETC	M5	0,5 - 2,5	7	10	6,9	1	18,5	13,5	11500	2000	8,5
ICA2M5L2SETC	M5	2 - 4	7	10	6,9	1	20,5	13,5	11500	2000	8,5
ICA2M6L1SETC	M6	0,5 - 3	9	12,7	8,9	1,5	23	17	16500	3000	15
ICA2M6L2SETC	M6	3 - 5	9	12,7	8,9	1,5	25	17	16500	3000	15
ICA2M8L1SETC	M8	1 - 3,5	11	16	10,9	1,5	25	18,2	25000	4400	26
ICA2M8L2SETC	M8	3,5 - 5,5	11	16	10,9	1,5	27	18,2	25000	4400	26
ICA2M10L1SETC	M10	1 - 4	13	19	12,9	1,7	33	25	32000	5000	50
ICA2M10L2SETC	M10	4 - 6	13	19	12,9	1,7	35	25	32000	5000	50
ICA2M12L1SETC	M12	1 - 4	16	23	15,9	2	33,5	25	34000	6500	80
ICA2M12L2SETC	M12	4 - 6	16	23	15,9	2	35,5	25	34000	6500	80

STAINLESS STEEL A2 RIVET NUT OPEN - SEMI-HEXAGONAL REDUCED HEAD

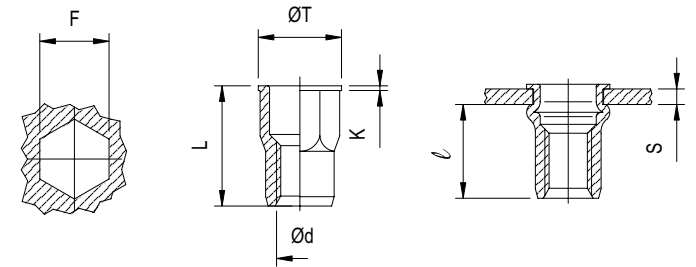
 IAA2M L1 SETFE
 IAA2M L2 SETFE

CODE	Thread Ød	S	ØF +0.10	Ø head (ØT)	Ø shank	K	L	ℓ	Tearing lead	cut	Max Torque Nm
IAA2M3L1SETFE	M3	0,5 - 1,5	5	6	4,9	0,5	9	5,2	3900	900	1
IAA2M3L2SETFE	M3	1,5 - 2,5	5	6	4,9	0,5	11	5,5	3900	900	1
IAA2M4L1SETFE	M4	0,5 - 2	6	7	5,9	0,5	12	8	6800	1500	3
IAA2M4L2SETFE	M4	2 - 4	6	7	5,9	0,5	14	8	6800	1500	3
IAA2M5L1SETFE	M5	0,5 - 2,5	7	8	6,9	0,6	13	8,2	11500	2000	6
IAA2M5L2SETFE	M5	2 - 4	7	8	6,9	0,5	15	8,2	11500	2000	6
IAA2M6L1SETFE	M6	1 - 3	9	10	8,9	0,6	16	10,7	16500	3000	11
IAA2M6L2SETFE	M6	3,5 - 5	9	10	8,9	0,6	18	10,7	16500	3000	11
IAA2M8L1SETFE	M8	1 - 3,5	11	12	10,9	0,65	17,5	11,2	25000	4400	20
IAA2M8L2SETFE	M8	3,5 - 5	11	12	10,9	0,65	19,5	11,2	25000	4400	20
IAA2M10L1SETFE	M10	1 - 4	13	14,5	12,9	0,75	21	13,5	32000	5000	32
IAA2M10L2SETFE	M10	3,5 - 5	13	14,5	12,9	0,75	23	13,5	32000	5000	32
IAA2M12L1SETFE	M12	1 - 4	16	17,5	15,9	0,8	24	14,8	34000	6500	50
IAA2M12L2SETFE	M12	4 - 6	16	17,5	15,9	0,8	27	14,8	34000	6500	50

STAINLESS STEEL A2 RIVET NUT CLOSED - SEMI-HEXAGONAL REDUCED HEAD

ICA2M L1 SETFE
ICA2M L2 SETFE

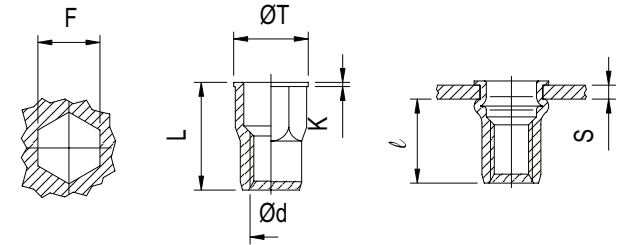

CODE	Thread Ød	S	ØF +0.10	Ø head (ØT)	Ø shank	K	L	ℓ	Tearing lead	cut	Max Torque Nm
ICA2M3L1SETFE	M3	0,5 - 1,5	5	6	4,9	0,5	13	8,5	3900	900	1
ICA2M3L2SETFE	M3	1,5 - 2,5	5	6	4,9	0,5	15	8,5	3900	900	1
ICA2M4L1SETFE	M4	0,5 - 2	6	7	5,9	0,5	15,5	11,5	6800	1500	3
ICA2M4L2SETFE	M4	2 - 4	6	7	5,9	0,5	17,5	11,5	6800	1500	3
ICA2M5L1SETFE	M5	0,5 - 2,5	7	8	6,9	0,5	18	13,5	11500	2000	6
ICA2M5L2SETFE	M5	2 - 4	7	8	6,9	0,5	20	13,5	11500	2000	6
ICA2M6L1SETFE	M6	0,5 - 3,5	9	10	8,9	0,6	21,5	15,8	16500	3000	11
ICA2M6L2SETFE	M6	3,5 - 5	9	10	8,9	0,6	23	15,8	16500	3000	11
ICA2M8L1SETFE	M8	1 - 3,5	11	12	10,9	0,65	24	18,2	25000	4400	20
ICA2M8L2SETFE	M8	3,5 - 5,5	11	12	10,9	0,65	26	18,2	25000	4400	20
ICA2M10L1SETFE	M10	1 - 4	13	14,5	12,9	0,75	30,5	23,2	32000	5000	32
ICA2M10L2SETFE	M10	3,5 - 6	13	14,5	12,9	0,75	33	23,2	32000	5000	32
ICA2M12L1SETFE	M12	1 - 4	16	17,5	15,9	0,75	31.50(31.00)	23,2	34000	6500	50

STAINLESS STEEL A2 RIVET NUT OPEN - SEMI-HEXAGONAL CYLINDRICAL HEAD

IAA2M L1 SETFC
IAA2M L2 SETFC

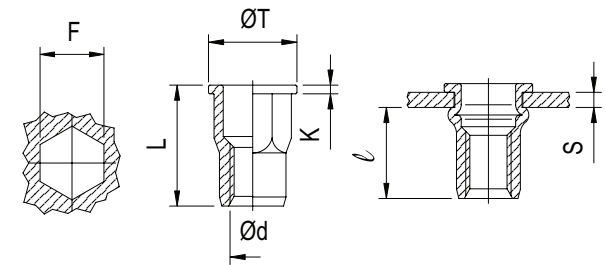

CODE	Thread Ød	S	ØF +0.10	Ø head (ØT)	Ø shank	K	L	ℓ	Tearing lead	cut	Max Torque Nm
IAA2M4L1SETFC	M4	0,5 - 2	6	7,2	5,9	0,5	11,2	6	9000		7
IAA2M5L1SETFC	M5	0,5 - 3	7	8,2	6,9	0,5	13,3	8	12000		11
IAA2M6L1SETFC	M6	0,5 - 3	9	10,5	8,9	0,6	15,3	10	23000		21
IAA2M8L1SETFC	M8	0,5 - 3,5	11	13	10,9	0,7	16,7	12	30000		35
IAA2M10L1SETFC	M10	1 - 3,5	13	15	12,9	0,8	21	15	38000		50

STAINLESS STEEL A2 RIVET NUT OPEN - HEXAGONAL SHANK CYLINDRICAL HEAD

IAA2M L1 TETC

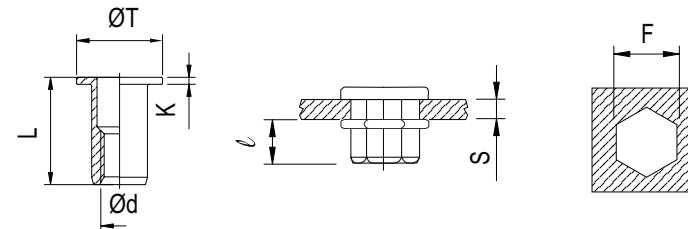

CODE	Thread Ød	S	ØF +0.10	Ø head (ØT)	Ø shank	K	L	ℓ	Tearing lead	cut	Max Torque Nm
IAA2M3L1TETC	M3	0,5 - 1,5	5	7,50	4,90	0,80	9,00	5,5	3900	900	2
IAA2M4L1TETC	M4	0,5 - 2	6	9,00	5,90	0,80	11,00	6,5	6800	1500	5
IAA2M5L1TETC	M5	0,5 - 2,5	7	10,00	6,90	1,00	14,00	8	11500	2000	8,5
IAA2M6L1TETC	M6	0,5 - 3	9	12.70(13.00)	8,90	1,35	15.00(16.00)	8,5	16500	3000	15
IAA2M8L1TETC	M8	1 - 3,5	11	16,00	10,90	1,50	18,00	10,5	25000	4400	26
IAA2M10L1TETC	M10	1 - 3,5	13	18.00(19.00)	12,90	1,70	21.00(23.00)	12,5	32000	5000	50
IAA2M12L1TETC	M12	1 - 4	15	20,00	14,90	1,70	23,00	14	34000	6500	80

STAINLESS STEEL A2 RIVET NUT CLOSED - HEXAGONAL SHANK CYLINDRICAL HEAD

ICA2M L1 TETC

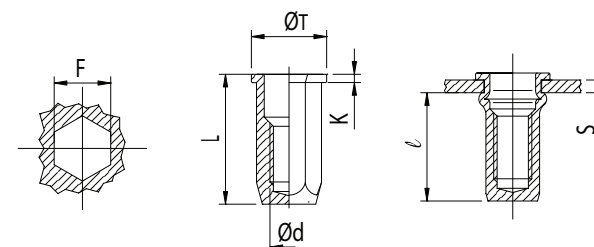

CODE	Thread Ød	S	ØF +0.10	Ø head (ØT)	Ø shank	K	L	ℓ	Tearing lead	cut	Max Torque Nm
ICA2M4L1TETC	M4	0,5 - 2	6,00	9,00	5,90	1,00	15,00	11,00	6800	1500	5
ICA2M5L1TETC	M5	0,50 - 2,50	7,00	10,00	6,90	1,00	18,00	13,50	11500	2000	8,5
ICA2M6L1TETC	M6	0,50 - 3	9,00	12,70	8,90	1,50	23,00	17,00	16500	3000	15
ICA2M8L1TETC	M8	1,00 - 3,50	11,00	16,00	10,90	1,50	26,00	19,00	25000	4400	26
ICA2M10L1TETC	M10	1,00 - 4	13,00	19,00	12,90	2,00	33,00	25,00	32000	5000	50

STAINLESS STEEL A2 RIVET NUT OPEN - HEXAGONAL SHANK REDUCED HEAD

IAA2M L1 TETF

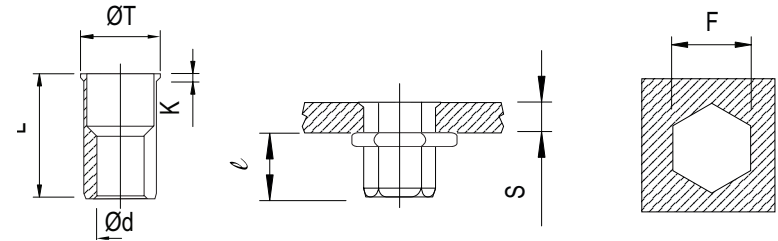

CODE	Thread Ød	S	ØF +0.10	Ø head (ØT)	Ø shank	K	L	l	Tearing lead	cut	Max Torque Nm
IAA2M3L1TETF	M3	0,5 - 1,5	5	6	4,9	0,5	8,5	5	3900	900	1
IAA2M4L1TETF	M4	0,5 - 2,5	6	7	5,9	0,5	11	6,7	6800	1500	3
IAA2M5L1TETF	M5	0,5 - 3	7	8	6,9	0,5	14,5	9	11500	2000	6
IAA2M6L1TETF	M6	1 - 3,5	9	10	8,9	0,6	16	10	16500	3000	11
IAA2M8L1TETF	M8	1 - 4	11	12	10,9	0,65	18	11,5	25000	4400	20
IAA2M10L1TETF	M10	1 - 3,5	12	13,5	11,9	0,75	19	12,5	32000	5000	32
IAA2M12L1TETF	M12	1 - 4	16	17,5	15,9	1	25	15,5	34000	6500	50

STAINLESS STEEL A2 RIVET NUT CLOSED - HEXAGONAL SHANK REDUCED HEAD

ICA2M L1 TETF

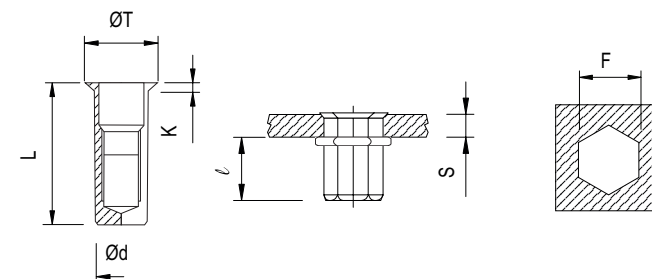

CODE	Thread Ød	S	ØF +0.10	Ø head (ØT)	Ø shank	K	L	ℓ	Tearing lead	cut	Max Torque Nm
ICA2M4L1TETF	M4	0,5 - 2,5	6	7	5,9	0,5	16	12,3	6800	1500	3
ICA2M5L1TETF	M5	0,5 - 3	7	8	6,9	0,5	20	15,2	11500	2000	6
ICA2M6L1TETF	M6	0,5 - 3,5	9	10	8,9	0,6	20,5	14,5	16500	3000	11
ICA2M8L1TETF	M8	1 - 4	11	12	10,9	0,65	23	17	25000	4400	20
ICA2M10L1TETF	M10	1 - 4,5	13	14,5	12,9	0,75	28,5	20	32000	5000	32

ALUMINIUM RIVET NUT OPEN - FLAT SHANK CYLINDRICAL HEAD

IAALM L1 CLTC

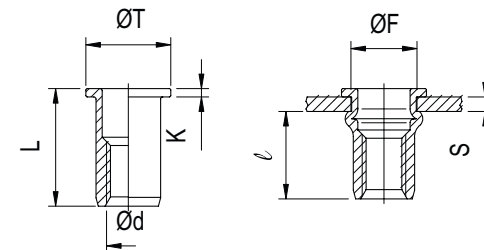

CODE	Thread Ød	S	ØF +0.10	Ø head (ØT)	Ø shank	K	L	ℓ	Tearing lead	cut	Max Torque Nm
IAALM4L1CLTC	M4	0,5 - 2	6	8,8	5,9	0,8	10,5	6	4000	600	2,5
IAALM5L1CLTC	M5	0,5 - 2,5	7	10	6,9	1	13	7,5	6500	1200	5
IAALM6L1CLTC	M6	0,5 - 2,5	9	12,3	8,9	1,3	15	9,2	7800	2000	8
IAALM8L1CLTC	M8	1 - 3	11	14,3	10,9	1,5	16,5	10,2	12300	2400	20
IAALM10L1CLTC	M10	1 - 4	13	16,3	12,9	1,6	19	11,5	17500	3600	25

ALUMINIUM RIVET NUT OPEN - FLAT SHANK REDUCED HEAD

IAALM L1 CLTF

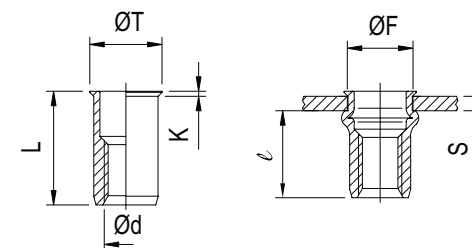

CODE	Thread Ød	S	ØF +0.10	Ø head (ØT)	Ø shank	K	L	ℓ	Tearing lead	cut	Max Torque Nm
IAALM4L1CLTF	M4	0,5 - 2	6	7	5,9	0,5	10,5	6	4000	600	2,5
IAALM5L1CLTF	M5	0,5 - 2	7	8	6,9	0,5	11,5	7,5	6500	1200	5
IAALM6L1CLTF	M6	0,5 - 2,5	9	10	8,9	0,6	14	9,2	7800	2000	8
IAALM8L1CLTF	M8	0,5 - 2,5	11	12	10,9	0,65	15,5	10,2	12300	2400	20
IAALM10L1CLTF	M10	1 - 3	13	14,1	12,9	0,7	17,7	11,5	17500	3600	25

ALUMINIUM RIVET NUT OPEN - KNURLED SHANK REDUCED HEAD

IAALM L1 CZTF

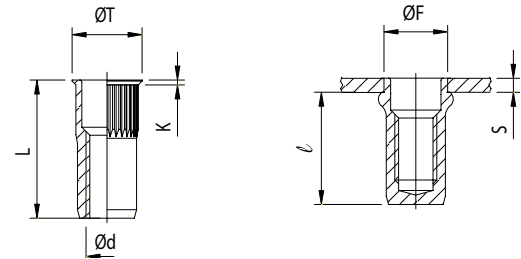

CODE	Thread Ød	S	ØF +0.10	Ø head (ØT)	Ø shank	K	L	ℓ	Tearing lead	cut	Max Torque Nm
IAALM4L1CZTF	M4	0,5 - 2	6	7	5,9	0,5	10,5	6	4000	600	2,5
IAALM5L1CZTF	M5	0,5 - 2	7	8	6,9	0,5	11,5	7,5	6500	1200	5
IAALM6L1CZTF	M6	0,5 - 2,5	9	10	8,9	0,6	14	9,2	7800	2000	8
IAALM8L1CZTF	M8	0,5 - 2,5	11	12	10,9	0,65	15,5	10,2	12300	2400	20
IAALM10L1CZTF	M10	1 - 3	13	14,1	12,9	0,7	17,7	11,5	17500	3600	25

ALUMINIUM RIVET NUT OPEN - KNURLED SHANK CYLINDRICAL HEAD

IAALM L1 CZTC

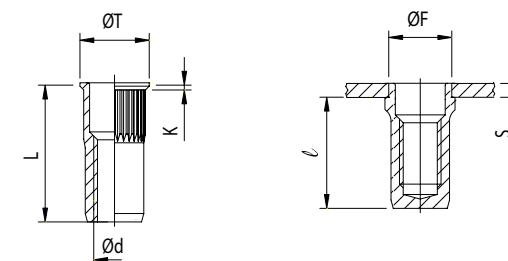

CODE	Thread Ød	S	ØF +0.10	Ø head (ØT)	Ø shank	K	L	ℓ	Tearing lead	cut	Max Torque Nm
IAALM4L1CZTC	M4	0,5 - 2	6	8,8	5,9	0,8	10,5	6	4000	600	2,5
IAALM5L1CZTC	M5	0,5 - 2,5	7	10	6,9	1	13	7,5	6500	1200	5
IAALM6L1CZTC	M6	0,5 - 2,5	9	12,3	8,9	1,3	15	9,2	7800	2000	8
IAALM8L1CZTC	M8	1 - 3	11	14,3	10,9	1,5	16,5	10,2	12300	2400	20
IAALM10L1CZTC	M10	1 - 4	13	16,3	12,9	1,6	19	11,5	17500	3600	25

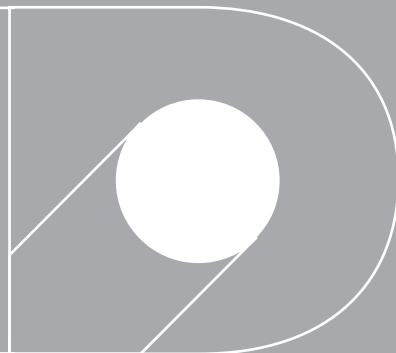

DEFREMM
COLD FORMING **EXPERT**

Via Goito, 6 - 23900 Lecco LC

Tel. (+39) 0341 251410

www.defremm.it - info@defremm.it